

REQUEST FOR PROPOSAL
CITY HALL REFURBISHMENT

PROJECT

City of Roseville
City Hall Refurbishment

AEW Project No. 0100-0508

OWNER

City of Roseville
29777 Gratiot Ave.
Roseville, Michigan 48066

LOCATION

Roseville City Hall
29777 Gratiot Ave.
Roseville, Michigan 48066

ARCHITECT/ENGINEER

Anderson, Eckstein and Westrick, Inc.
51301 Schoenherr Road
Shelby Township., Michigan 48315
(586) 726-1234

DESCRIPTION

The scope of work involved for this project is as follows:
Refurbishment of existing City Hall administration offices, approx. 15,000 sq. ft. Work includes the replace of finishes, carpet, wall covering, ceiling gird, and lighting. The existing service counter will be removed and replaced with new, added security windows and roll down gates in some areas. The building will remain occupied and functioning during construction.

SCOPE OF PROPOSAL

Sealed proposals are invited for the Project and will be received at the Office of the Owner until 11:00 am, local time; **September 29, 2022**. Bids will be publicly opened and read aloud in the offices of the Purchasing Dept.

PRE-BID MEETING

A mandatory pre-bid meeting will be held at the Roseville City Hall, 29777 Gratiot Ave, at 10:00 am **September 8, 2022**. Pre-bid questions shall be submitted to the Architect before **September 15, 2022**, 1:00 pm, local time. Questions may be submitted to Scott Kelley at: skelley@awinc.com, please write "Roseville City Hall – Office Renovation" in the subject line of the email.

DOCUMENTS

Documents and requirements will be available **August 24, 2022** after 1:00pm. This solicitation, along with all attachments may be downloaded from the Michigan Intergovernmental Trade Network (MITN) at www.mitn.info. Any and all Addenda

CITY OF ROSEVILLE
CITY HALL REFURBISHMENT
AEW PROJECT #0100-0508

AUGUST 12, 2022

issued by the City of Roseville must be viewed or downloaded from the above listed website.

BID GUARANTEE AND CONTRACT SECURITY

Each bid proposal shall be accompanied by a certified check, bank draft or satisfactory bid bond in an amount of 5% of the maximum bid amount. Checks shall be made payable to the City of Roseville. Bids may not be withdrawn for a period of sixty (60) calendar days after receipt of bids. The successful bidder will be required to furnish the required insurance and bond certificates.

RIGHTS OF THE OWNER

The Owner reserves the right to reject any or all proposals and to waive irregularities in bidding, or to accept the lowest responsible proposal that, in the opinion of the Owner, will serve his best interest.

DATED: August 2022

City of Roseville

DOCUMENT 00 91 00

ADDENDA

ADDENDUM NUMBER 1

DATE: August 29, 2022

PROJECT: City of Roseville City Hall Refurbishment

PROJECT NUMBER: 0100-0508

OWNER: City of Roseville

ARCHITECT/ENGINEER: Anderson, Eckstein & Westrick, Inc.

TO: Prospective Bidders

This Addendum forms a part of the Contract Documents and modifies the Bidding Documents dated 8/12/2022, with amendments and additions noted below.

This Addendum consists of (3) total pages.

The following changes to and/or clarifications of the Contract Documents will be incorporated in said Contract Documents and such changes shall be allowed for in the price bid by the Contractor, such that the price indicated in the Proposal shall represent the conditions as set forth in the original Contract Documents as modified by this Addendum.

Acknowledgment of receipt of this Addendum and the Bidder's Acceptance of these revised conditions prior to submittal of the bid shall be indicated by adding the Addendum number in the space provided in the Bid Form. Failure to do so may disqualify the Bidder.

A. BIDDER QUESTIONS AND RESPONSES:

None at this time

B. DOCUMENT REVISIONS:

a. Sheet A401: Added sheet missing from the 8/12/2022 bid documents

C. SUBSTITUTIONS:

a. SPECIFICATION SECTION 00 20 00 – Request for Proposal:
1. No changes, issued separately for clarity

D. ATTACHMENTS:

a. 00 20 00 – Request for Proposal
b. Sheets A401

End of Addenda



ANDERSON, ECKSTEIN AND WESTRICK, INC.

CIVIL ENGINEERS SURVEYORS ARCHITECTS

51301 Schoenherr Road Phone 586 726 1234
Shelby Township Michigan 48315 Fax 586 726 8780

www.aewinc.com

ENGINEERING STRONG COMMUNITIES

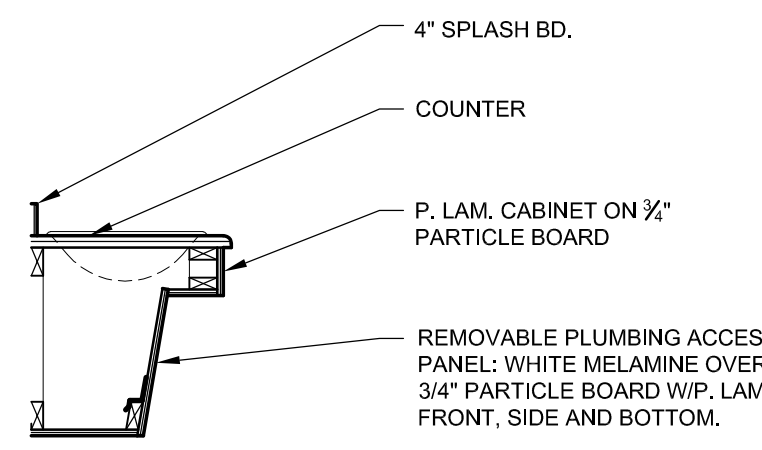

6 SECTION (ADA COMPLIANT)
A401 SCALE: 1/2" = 1'-0"

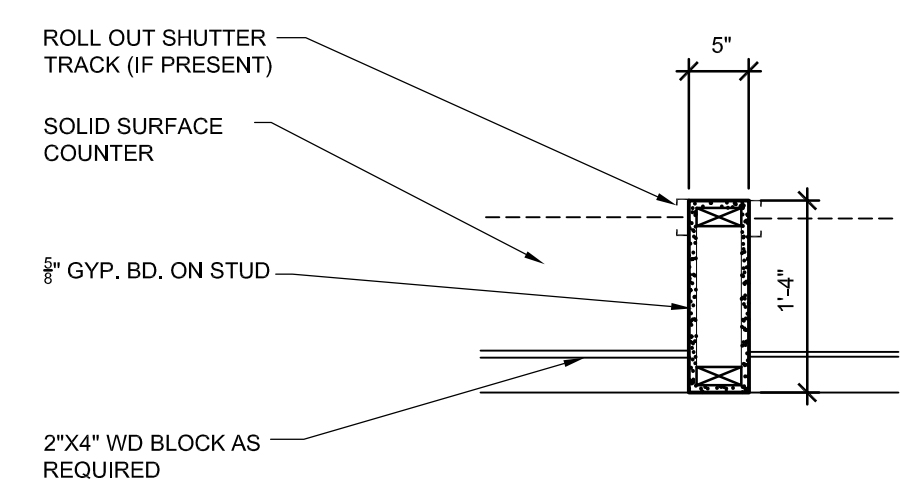

3 PLAN DETAIL
A411 SCALE: 1/4" = 1'-0"

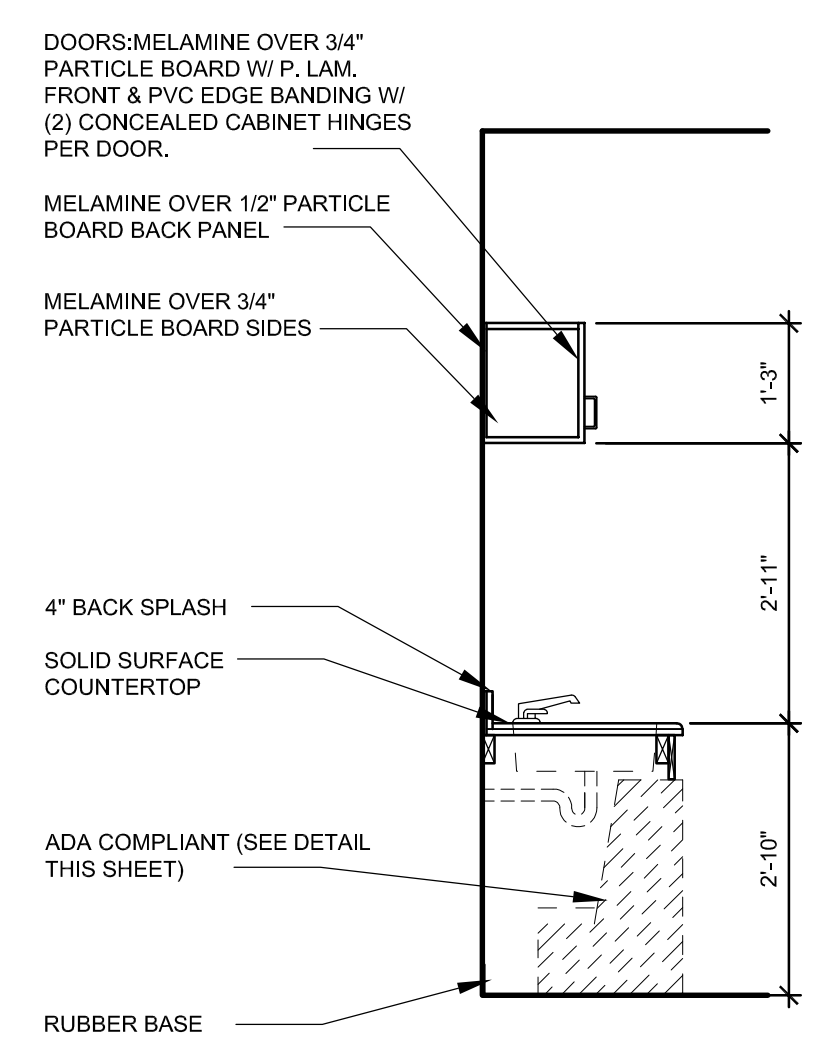

5 TYP. CABINET SECTION
A401 SCALE: 1/2" = 1'-0"

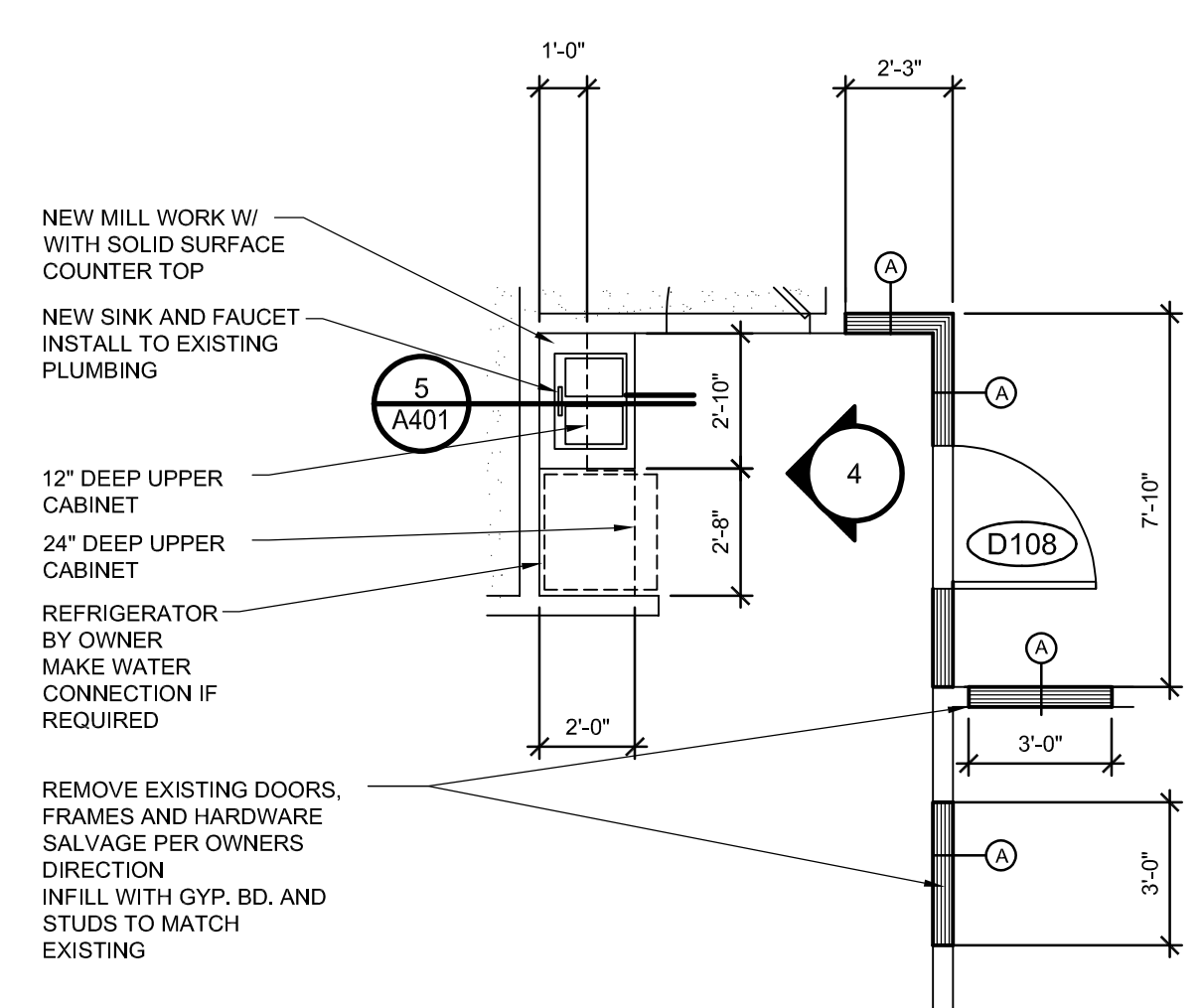

4 ENLARGED PLAN
A101 SCALE: 1/4" = 1'-0"

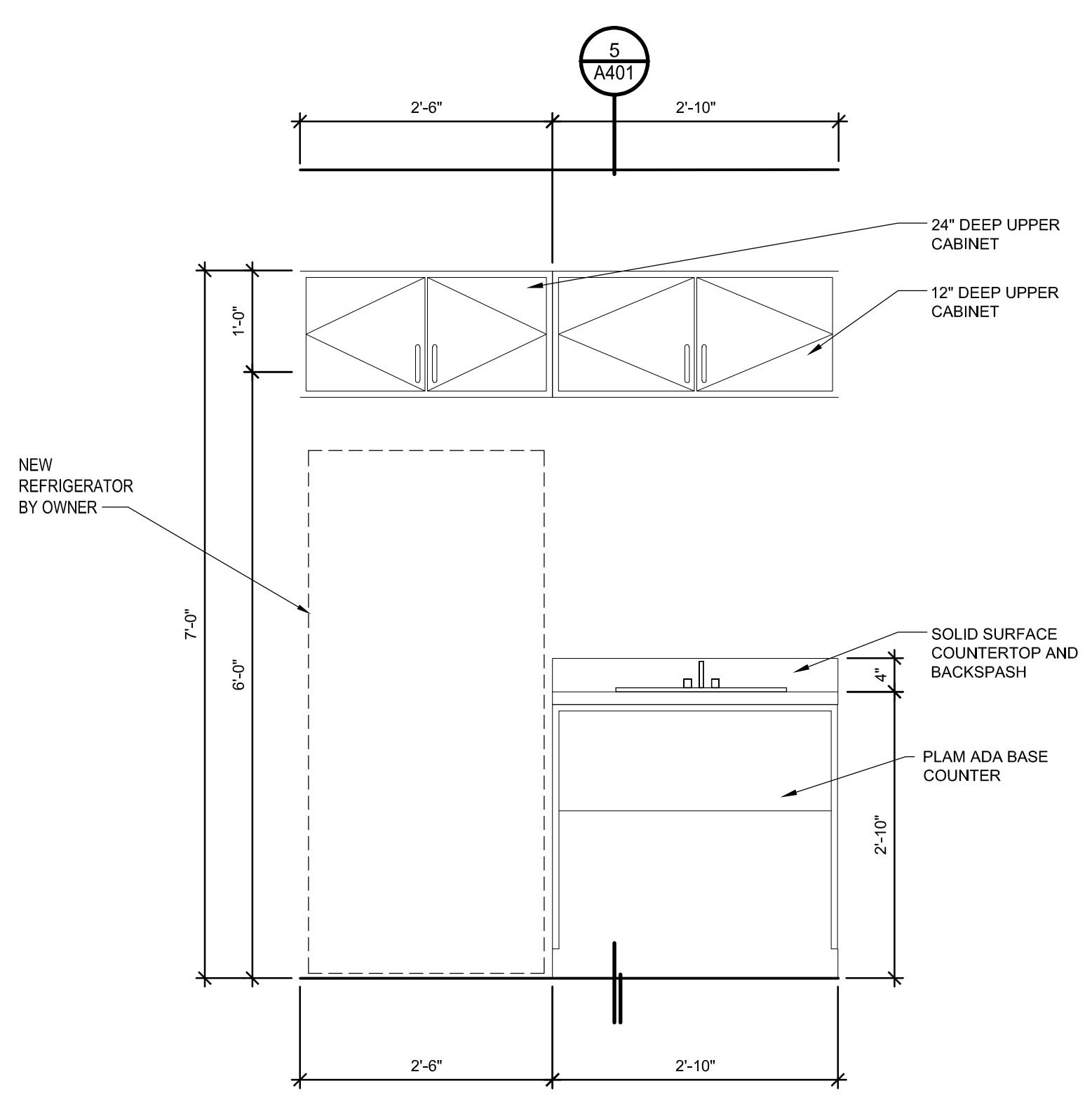

4 CONFERENCE RM 125 KITCHENETTE
A401 SCALE: 3/4" = 1'-0"

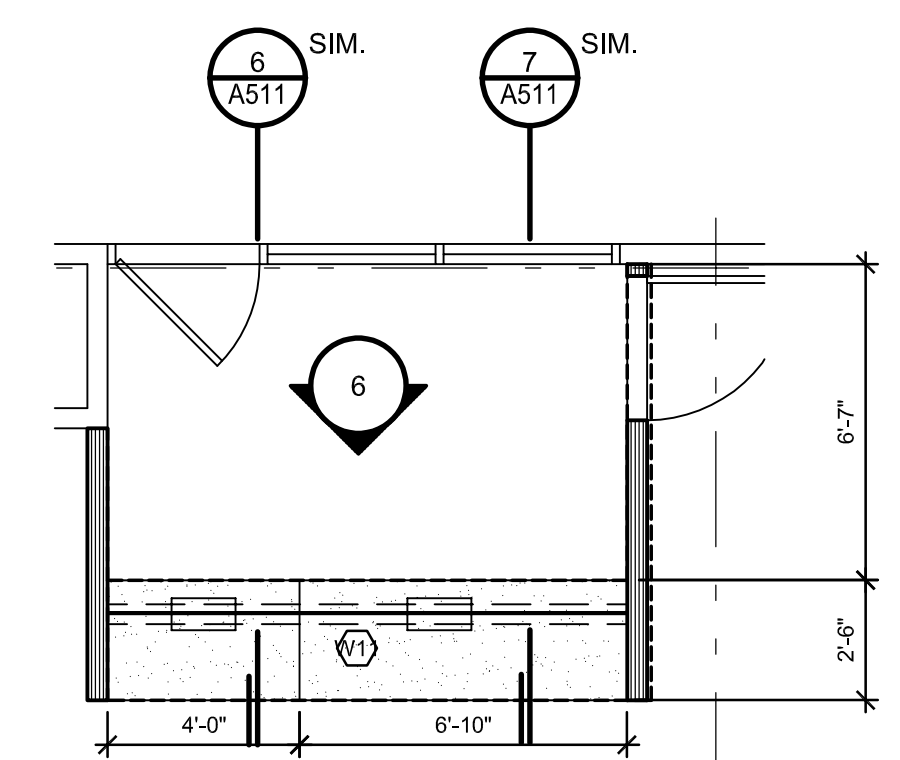

1 ENLARGED PLAN
A101 SCALE: 1/4" = 1'-0"

08/29/2022	ADDENDUM #1
08/12/2022	BID ISSUE
09/21/2022	90% REVIEW
DATE	SUBMITTALS/REVISIONS

PROJECT NAME:

CITY HALL REFURBISHMENT

SHEET TITLE:

PLAN DETAILS

CLIENT: CITY OF ROSEVILLE

<input checked="" type="checkbox"/> PRELIMINARY	<input type="checkbox"/> CONSTRUCTION	<input type="checkbox"/> RECORD
<input type="checkbox"/> CITY REVIEW		
DRAWN BY: JRA	CHECKED BY: JRA	DATE: AUGUST 2022

SCALE:



UTILITY INFORMATION, AS SHOWN, INDICATES APPROXIMATE LOCATIONS AND TYPES OF EXISTING FACILITIES ONLY, AS DISCLOSED BY RECORDS PROVIDED TO THIS FIRM FROM THE VARIOUS UTILITY COMPANIES. NO GUARANTEE IS GIVEN OR IMPLIED AS TO THE COMPLETENESS OR ACCURACY THEREOF.

PRIOR TO CONSTRUCTION, ALL LOCATIONS AND DEPTHS OF EXISTING OVERHEAD AND UNDERGROUND UTILITIES (IN CONFLICT WITH THE CONSTRUCTION OF THESE PROPOSED IMPROVEMENTS) SHALL BE VERIFIED IN THE FIELD, DURING THE CONSTRUCTION, THE CONTRACTOR SHALL PROTECT AND SUPPORT ALL UTILITIES THAT ARE ENCOUNTERED. (ALL COSTS FOR UTILITY LOCATION VERIFICATION, SUPPORT AND PROTECTION SHALL BE INCLUDED IN THE PROPOSED PAY ITEM CONFLICTING WITH THAT UTILITY).

DURING CONSTRUCTION, THE CONTRACTOR SHALL USE EXTREME CAUTION WHEN OPERATING NEAR ANY AND ALL OVERHEAD AND / OR BURIED UTILITIES.

PROJECT NO. 0100-0508

M:\0100\0100-0508\DWG\ARCH\ARCHSHEETS.DWG
A401--8/29/2022 9:32:35 AM

SHEET NO.

A401

COPYRIGHT, 2022, ANDERSON, ECKSTEIN AND WESTRICK, INC.